



**HIRED-HAND®**



# Farm Hand Vent Master 24

24 Stage Environmental Controller

Hired Hand, Inc.  
1733 Co Rd 68  
PO Box 99  
Bremen, AL 35033

# Table of Contents

Section	Title	Page
1.	Ratings and Specifications .....	1
2.	Warnings .....	1
3.	Limited Warranty .....	1
4.	Introduction .....	2
5.	Static Pressure Overview.....	3
6.	Why Use a Pressure Controller? .....	3
7.	Pressure Ramping (Optional) Explanation.....	4
8.	Day to Day Operating Instructions.....	5
8.1	Checking/Adjusting Temperatures, and Timer Percentages.....	5
8.2	Running Inlet Machines .....	7
8.3	Adjusting Stage On/OffPoints.....	7
9.	Program Mode.....	8
9.1	Sensors For Display (PSd).....	8
9.2	Stage Parameters .....	8
9.2.1	Stage Sensors (P1).....	8
9.2.2	Stage Mode (P2).....	9
9.2.3	Stage Timer Settings (P3).....	9
9.3	Vent Parameters.....	10
9.4	Pressure Ramping Parameters .....	10
9.5	Pressure Alarm Parameters.....	10
9.6	PC Compatible Network Parameters .....	11
9.7	Cool Timer Settings (ON/OFF Stages Only).....	11
9.8	Sensor Calibration .....	12
10.	Rarely Changed Settings .....	13
11.	Controller Installation and Setup.....	14
12.	Programming Examples .....	15
12.1	Setting Stage OnPoints and OffPoints.....	15
12.2	Setting up Stage Modes, and Timer Status.....	15
12.3	Setting Up Tunnel Control .....	16
12.4	Cool Timer Stage Operation.....	16
13.	Maintenance .....	17
14.	Wiring Diagrams, Schematics, etc. ....	17
14.1	Connecting the Vent Machines to the Vent Master 24.....	19
14.2	Connecting an SCST <sup>™</sup> Panel to the Vent Master 24 .....	20
14.3	Connecting Sensors to the Vent Master 24 .....	21
14.4	Connecting AC Power to the Vent Master 24 .....	22
14.5	Connecting the Vent Master 24 to a Data Shuttle .....	23
14.6	Connecting the Vent Master 24 to a Static Pressure Monitor.....	24
14.7	Connecting the Vent Master 24 to a Series or Parallel Alarm.....	25
15.	Program Reference .....	26
16.	Error Codes .....	29
16.1	Descriptions.....	29
16.2	Local Network Overview of Control System Devices .....	30
16.3	Possible Solutions.....	32
16.4	Temperature vs. Sensor Resistance Table .....	33
17.	Program Parameter Listing.....	34
18.	Error Code Listing.....	35
19.	Program Data Sheet.....	36

## 1. Ratings and Specifications

- 115/230 Volts (Depending on switch position.)
- 50/60 Hz.
- 8 Amps per vent machine.
- Room must be kept above 32°F/0°C and below 122°F/50°C.

## 2. Warnings

### **Warning!**

Before connecting power to the machine, be sure to check the position of the voltage selector switch located next to the transformer on the relay board. Improper positioning of this switch will cause system failure.

### **Warning!**

When this controller is used in a life support heating and ventilation system where failure could result in loss or injury, the user should provide adequate back-up, or accept the risk of such loss or injury!

## 3. Limited Warranty

All products are warranted to be free from defects in material and workmanship for a period of one year from the date of purchase if installed and used in strict accordance with the installation instructions. Liability is limited to the sale price of any products proved to be defective or, at manufacturers option, to the replacement of such products upon their return. No products are to be returned to the manufacturer, until there is an inspection and/or a return-goods authorization (RGA) number is issued.

All complaints should be directed first to the authorized distributor who sold the product. If satisfaction is not obtained or the name of the distributor is not known, write the manufacturer that appears below, directed to the attention of Customer Service Manager.

This limited warranty is expressly in lieu of any and all representations and warranties expressed or implied, including any implied warranty of merchantability or fitness for a particular purpose. The remedy set forth in this limited warranty shall be the exclusive remedy available to any person. No person has authority to bind the manufacturer to any representation or warranty other than this limited warranty. The manufacturer shall not be liable for any consequential damages resulting from the use of our products or caused by any defect, failure or malfunction of our products. (Some areas do not allow the exclusion or limitation of incidental or consequential damages, so the above limitation or exclusion may not apply to you.)

This warranty gives you specific legal rights and you may also have other rights that vary from area to area.

### **Warrantor:**

Hired-Hand, Inc.  
1733 Co. Rd. 68  
PO Box 99  
Bremen, AL 35033

## 4. Introduction

There is currently one model of the Vent Master 24 controller and it is used exclusively with the Farm Hand SCS™ 24 Smart Control System:

- (1) Farm Hand Vent Master 24 without Variable Speed

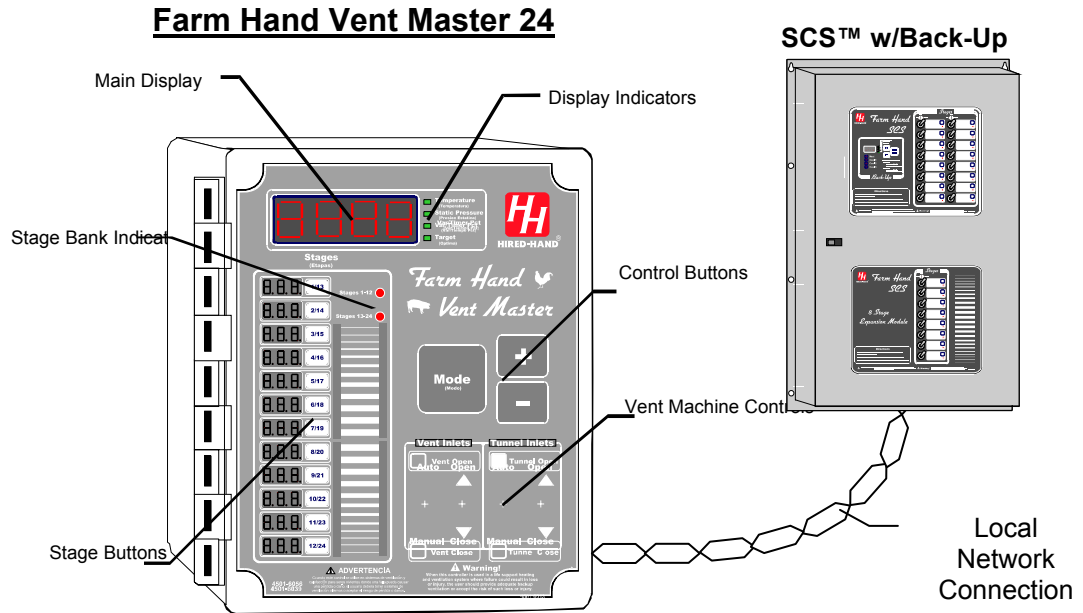

The Farm Hand Vent Master 24 Stage Controller is designed to be one of the simplest controllers on the market to operate, but to also be one of the most powerful. The Vent Master 24 combines the features of the Farm Hand Stage Master 12 with the capabilities of the Farm Hand Power Vent into a single controller. The Vent Master 24 works in combination with the Farm Hand SCS™ Panel by communicating over the Local Network connection.

The Vent Master 24 has four main regions on the faceplate: the main display, stage displays, the control button region and the vent machine control region. The main display area includes the main display, and four green LED's which tell what the main display is indicating. If the green light beside "Temperature" is lit, then the display is showing the display option chosen in the Program Mode under the parameter **PSd**. Refer to Section 6.1 for an explanation of the **PSd** parameter.

On the left hand side of the controller face are the stage displays. When the controller is operating, the OnPoint of each stage (the temperature the stage will turn on) is displayed. Next to the stage indicators, is a button imprinted with the number of the stage. Press this button to set the On and OffPoints for that stage. (Stage OnPoints and OffPoints are discussed later in the manual.) Near the top of the Stage Status indicators are two red LEDs that indicate which bank of Stages is being indicated in the Stage Status indicators. The upper Led is On for Stages 1 through 12 and the bottom LED is on for Stages 13-24.

Just below the main display on the right hand side of the controller is the control button region. This region has three buttons: Mode, Plus (+), and Minus (-). You will learn the use of these three buttons later in this manual.

Finally, on the bottom right hand side of the controller is the Inlet machine control region. This region includes an Automatic/Manual switch and an Open/Off/Close switch for the Tunnel Inlet machine and the Vent Inlet machine.

## 5. Static Pressure Overview

The Farm Hand Vent Master 24 has been designed with the producer in mind. Routine tasks such as changing the pressure limits are easily reset, and are familiar in nature.

The Vent Master 24 has two basic pressure settings, a Target Pressure, and a Pressure Differential. The Target Pressure is the static pressure that the system tries to maintain within the limits of the Pressure Differential. The Pressure Differential is the range around the Target Pressure that is considered satisfactory. From the Target Pressure and the Pressure Differential the High and Low Pressure limits are calculated. The High Pressure limit is the Target Pressure plus half of the Pressure Differential and the Low Pressure limit is the Target Pressure minus half of the Pressure Differential. The controller will open and close the vents as needed to maintain pressure between the high and low limits.

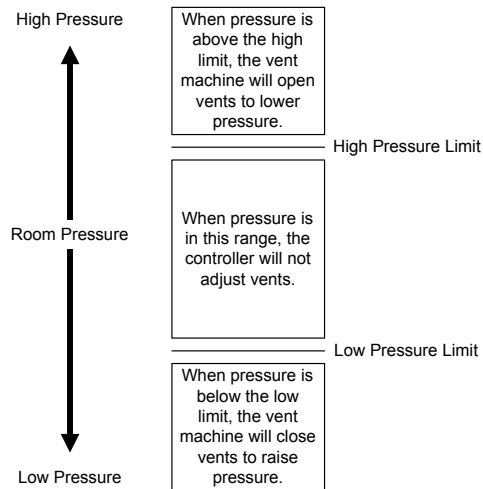

Now that we know how the pressure limits are established, let's move on to how to set up those limits.

Press the mode button a few times, and you will see that the display changes each time. If you will look just to the right of the display, you will see four green lights labeled Temperature, Static Pressure, Var/Timer Percent, and Target. The green light tells you what setting you are looking at in the main display. If the light beside Static Pressure is lit, the numbers in the display show you the current pressure in your building. However, for viewing Target Temperature both the LEDs beside "Target" and "Temperature" will be lit. For viewing Target Static Pressure both the LEDs beside "Target" and "Static Pressure" will be lit.

Assume that you have this controller installed in your house, and you decide you want pressure to be kept a little bit lower. You walk to the controller, press and release the mode button, watching the green lights until the "Target" and "Static Pressure" LED is lit. If you look at the display now, you see the present setting for the Target Pressure. To lower it, press and release the minus (-) button until you see the new limit you want. The controller will now start operating using your new limit. If you want the Vent Master 24 to maintain the Target Pressure within narrower limits decrease the Pressure Differential. See Section 7 for a graphic example using the Target Pressure and Pressure Differential.

## 6. Why Use a Pressure Controller?

The Farm Hand Vent Master 24 is used to control vent inlets in agricultural enclosures. Maintaining a slight negative pressure inside a building ensures that air flows in evenly from all openings in the building. However, as static pressure increases, the speed and volume of the incoming air increases. It is important to set the pressure at an appropriate level to ensure maximum efficiency. Too little vacuum, and the livestock could suffer from drafting, and temperature shock. Too much vacuum, and fan efficiency is reduced, increasing the levels of moisture, ammonia in the enclosure, and also driving up electricity costs.

## 7. Pressure Ramping (Optional) Explanation

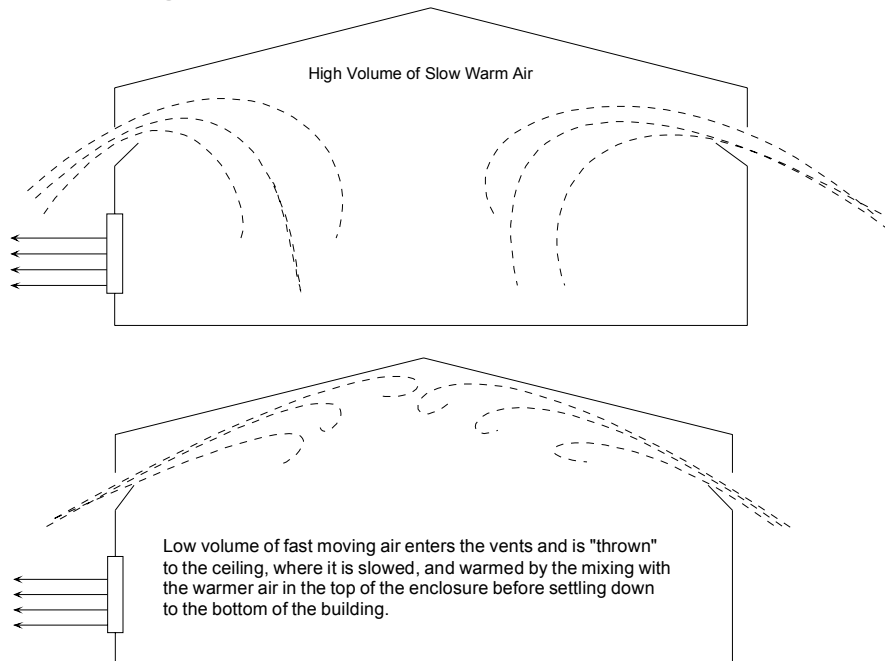

The above illustrations show the need for a different air flow rate when the temperature changes. This is accomplished with the ramping feature.

Ramping allows you to set a band of pressure to be maintained, taking into account the **OUTSIDE** temperature. (After all, outside air is what is flowing into the house.) If the outside temperature is warm, it will allow taking in a large volume of slow moving warm air (low static pressure), but when outside air is cold, the Vent Master 24 will adjust to allow a low volume of fast moving cold air (high static pressure).

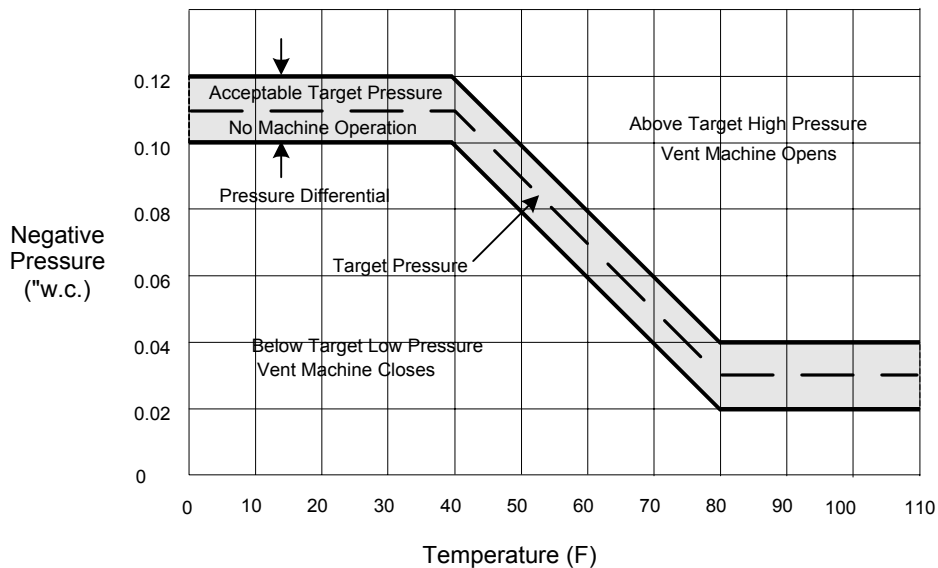

Using figures from the chart above; the controller was programmed as follows:

P21 = Pressure Differential	0.02" w.c.
P30 = Ramping Mode	ON
P31 = High Temperature Limit	80°F

P32 = High Temperature Target Pressure	0.03" w.c.
P34 = Low Temperature Limit	40°F
P35 = Low Temperature Target Pressure	0.11" w.c.

As you can see from the graph, if outside temperature is 50°F, the controller will try to maintain a static pressure between 0.08, and 0.1" w.c. If the pressure goes above 0.1" w.c. the vent machine will open, and reduce static pressure, and if the pressure goes below 0.08" w.c., the vent machine will close, increasing the static pressure.

## 8. Day to Day Operating Instructions

This section of the manual will give you all you need to know about the day to day operation of your controller.

### 8.1 Checking/Adjusting Temperatures, and Timer Percentages

When no one has pressed a button for over one minute, the display will automatically show the room temperature and the display indicator will indicate "Temperature". To see the Static Pressure, press the button labeled "Mode". This button is located in the center of the controller facepad. When this button is pressed, watch the green LED's beside the main display. Whenever a single LED is lit, this is the parameter you are viewing.

For viewing Target Temperature both the LEDs beside "Target" and "Temperature" will be lit. For viewing Target Static Pressure both the LEDs beside "Target" and "Static Pressure" will be lit.

#### Room Temperature

The temperature read by the sensor(s) chosen in the Program Mode under the parameter **PSd**. Refer to Section 9.1 for an explanation of the **PSd** parameter.

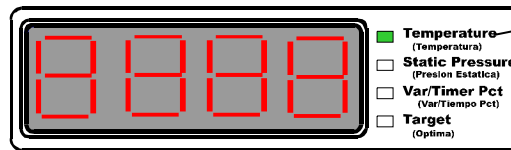

Temperature displays Room Temperature

#### Static Pressure

The static pressure sensed by the controller. While displaying the Static Pressure, the controller will also display the temperatures read by sensors 1, 2, 3 and 4 in the corresponding stage displays. The remaining stage displays will be blank at this time.

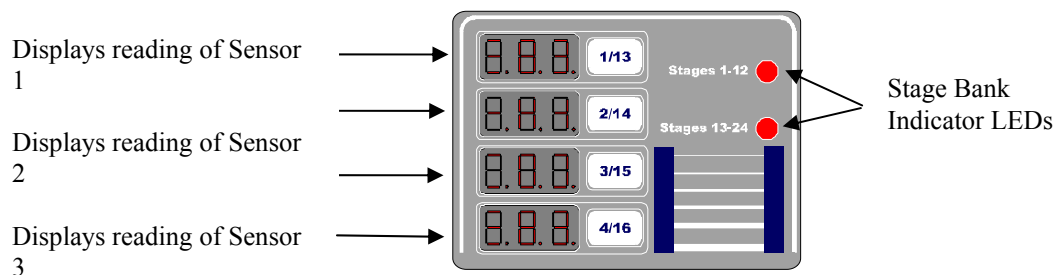

#### Timer Percentage

The Timer percentage parameter can be used to set *runtime percentage*. Runtime percentage refers to the percentage of the timer cycle that a stage on a timer will run.

For example, if the Timer Pct. is set for 30, and the timer cycle is set for 10 minutes, the timed stages will run for 3 minutes out of every 10 minutes (i.e. 30% of the timer cycle).

**Runtime Percentage**

The Timer Pct. parameter sets the Runtime percentage of all stages that are placed on a timer (See Section 9.2). The value of the Timer Pct. in the main display refers to a Runtime % which can be set to values between 5 and 100 using the "+" and "-" buttons.

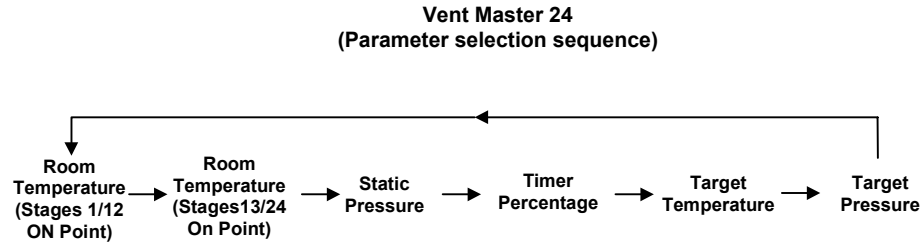

**Target Temperature**

The target temperature is the temperature the system tries to maintain.

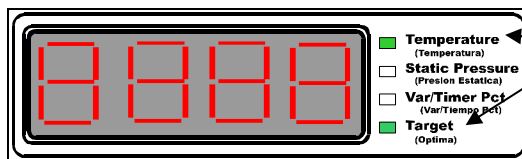

For Target Temperature, both the Target LED and the Temperature LED will be lighted.

To adjust these settings, press the mode button until you see the setting you want to adjust, then use the + button to raise the value, and the - button to lower the value. When you are finished setting a new value, either press the mode button again, or do nothing, and the system will return to normal operation within a few seconds.

**Target Static Pressure**

The Static Pressure the system tries to maintain within the limits of the Pressure Differential.

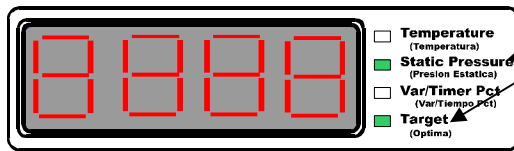

For Target Pressure, both the Target LED and the Static Pressure LED will be lighted.

To adjust the Target Static Pressure, press the mode button until you see the setting you want to adjust, then use the + button to raise the value, and the - button to lower the value. When you are finished setting a new value, either press the mode button again, or do nothing, and the system will return to normal operation within a few seconds.

The Pressure Differential is the range around the Target Pressure that is considered satisfactory. From the Target Pressure and the Pressure Differential the target high and low pressure limits are calculated as follows:

$$\text{Target High Pressure Limit} = \text{Target Pressure} + \frac{1}{2} \text{ Pressure Differential}$$

$$\text{Target Low Pressure Limit} = \text{Target Pressure} - \frac{1}{2} \text{ Pressure Differential}$$



## 8.2 Running Inlet Machines

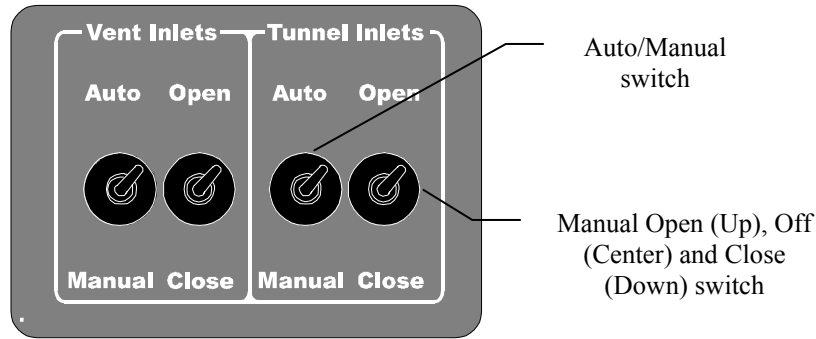

Under normal circumstances the machines should be left in automatic (Auto) as shown above. This way, if the controller needs to open the vents, it will open them. However, if you want to open or close them for any reason, do the following.

1. Find the switches for the machine you want to run, and check that the Open/Off/Close switch is in the Off position. This makes sure that the machine does not run until you want it to.
2. Place the Automatic/Manual switch for that machine in the “Manual” position.
3. To open the machine place the Open/Off/Close switch to the position marked “Open”.
4. To close the machine place the Open/Off/Close switch to the position marked “Close”.
5. Finally when you are finished positioning the machine, place the switch back into the “Off” position. Note: "Off" position is between "Open" and "Close".
6. When you are ready for the controller to take over control of the vents, return the Automatic/Manual switch to the automatic position.

## 8.3 Adjusting Stage On/OffPoints

If you decide that a fan stage comes on too soon, or waits until temperature is too high to come on, you can easily adjust that setting. To adjust the stage OnPoint, first select the desired Stage Bank. There are two Stage Banks, one containing Stages 1 through 12 and the second bank containing Stages 13 through 24. Which of these banks is being indicated in the 12 stage indicators is shown by the lighted Stage Bank LED at the top right. Press the Mode button until the Stage Bank indicator lights for the desired stage bank.

To adjust the stage OnPoint, press the numbered stage button one time. The individual stage display will flash, and the main display will flash between “On” and the Target Temperature. Use the + button to raise the value in the individual stage display until you see the correct temperature, or the - button to lower the value until the stage OnPoint is where you want it. When you are finished setting a new value, press the individual stage button again and the main display will read “OFF” and flash the target temperature. Use the + and/or - buttons until the correct setting shows in the individual stage display.

Notice that as you press the stage button the first time, all of the individual stage displays show their stage’s OnPoints. Only one stage will flash this reading. When you press the + and/or - button, you will only adjust that particular stage’s value. To adjust another stage, press that stage’s button.

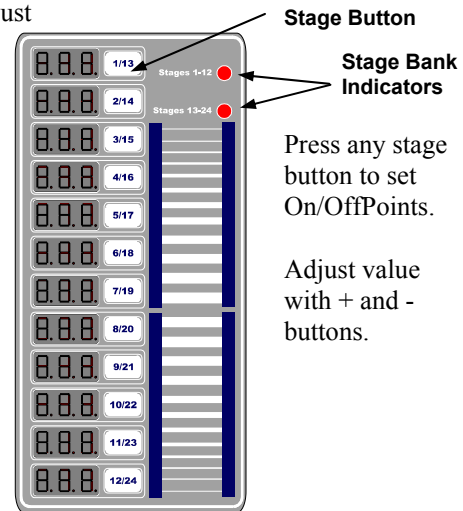

When you have finished setting your stage On/OffPoints press the individual stage button once more, and the system will not flash any stage displays, and the main display will read a steady value. Your Vent Master 24 is now operating normally again.

## 9. Program Mode

Settings that are usually set up once per growout, or maybe even just for summer or winter are referred to as program parameters and are accessed by taking the controller to program mode. Some examples of these settings are Vent Machine Time Delay, Runtime, Stages on Timers, and Sensor Calibration. To get to program mode, press and hold the “Mode” button for five seconds. When the controller has entered program mode, the main display will flash between “PSd” and the value of this parameter.

The “PSd” is known as a parameter number. All the program items for the controller have a parameter number assigned to them. The numbers are listed in the section called “Program Reference” in the back of this manual with a short description of each parameter. When in program mode, you change the current parameter by using the + and - buttons as needed. When you have finished with the current setting, press the “Mode” button to move to the next parameter.

### 9.1 Sensors For Display (PSd)

The user is given the choice as to what to display for **Room Temp**. The choice is made in Program Mode under the parameter **PSd**. The following is a list of choices:

**PSd = Room Temperature Display**

- 100 = Sensor 1
- 020 = Sensor 2
- 120 = Average of Sensors 1 & 2
- 003 = Sensor 3
- 103 = Average of Sensors 1 & 3
- 023 = Average of Sensors 2 & 3
- 123 = Average of Sensors 1, 2, & 3

### 9.2 Stage Parameters

The following parameters are used to program each stage on the Farm Hand Vent Master 24. Through these parameters, the user has complete control over the operation of each stage. The following sections explain each parameter in detail.

**P1 = Stage Sensors**

**P2 = Stage Mode**

**P3 = Stage Timer Settings**

#### 9.2.1 Stage Sensors (P1)

A stage can be programmed to run off of any sensor or combination of sensors. The following is the list of **P1** options:

**P1 = Stage Sensors**

- 100 = Sensor 1
- 020 = Sensor 2
- 120 = Average of Sensors 1 & 2
- 003 = Sensor 3
- 103 = Average of Sensors 1 & 3
- 023 = Average of Sensors 2 & 3
- 123 = Average of Sensors 1, 2, & 3

While in the Programming Mode and Parameter P1 is shown in the display, Stages 1/12 will be displayed first. Note the red LED next the Stages 1-12 is lighted. After setting P1 for Stages 1/12, press the Mode button to set stages 13/24.

## 9.2.2 Stage Mode (P2)

The Farm Hand Vent Master 24 is a very intelligent controller, therefore, it needs to not only know whether this is a heating or cooling stage but also what type of cooling stage. This feature allows the grower to program the cooling stages to work exactly like he wants them to without the expense of hard wiring through relays and limit switches. This feature allows the Farm Hand Vent Master 24 to better react to the environment. Any Stage can be programmed to be one of the following:

**1 = Heat (h1)**

This mode allows the equipment to operate when room temperature is below the OnPoint for the stage.

**2 = Cool Stir (c2)**

This mode setting is for cool stages that stir inside sir. This stage will not run during tunnel mode.

**3 = Cool Negative (c3)**

This mode setting is primarily for negative cross ventilation fans. This stage will not run during tunnel mode.

**4 = Cool Negative Tunnel (c4)**

This mode setting works exactly like the Cool Negative setting except it will run if the controller goes into tunnel mode. This stage is sometimes referred to as a transitional stage. In other words, it operates before it goes into tunnel and also during tunnel.

**5 = Cool Tunnel (c5)**

This mode setting only works when the controller is in tunnel mode.

While in the Programming Mode and Parameter P2 is shown in the display, Stages 1/12 will be displayed first. Note the red LED next the Stages 1-12 is lighted. After setting P2 for Stages 1/12, press the Mode button to set stages 13/24.

## 9.2.3 Stage Timer Settings (P3)

The Farm Hand Vent Master 24 is equipped to satisfy any of your minimum ventilation needs for regular runtime timers, to cool timers, to progressive timers.

**00 = No Timer**

Select 0 for the timer setting if you do not want the stage to be on a timer.

**01 = Runtime Timers**

Any one of the On/Off stages can be placed on the system timer by placing a "1" in parameter 3 (**P3**) of the stage. By doing this the stage will operate off of the system timer while the temperature is below the stage's OnPoint. Once the temperature reaches the stage OnPoint, the stage will come on full time.

**02 = Cool Timers**

**On/Off Stages**

Any one of the On/Off Stages can be placed on a cool timer. By doing this the stage will operate off the system timer only while the temperature is above the stage OffPoint (**OFF**). Refer to Section 12.4 "Cool Timer Stage Operation" for proper setup.

While in the Programming Mode and Parameter P3 is shown in the display, Stages 1/12 will be displayed first. Note the red LED next the Stages 1-12 is lighted. After setting P3 for Stages 1-12, press the Mode button to set stages 13-24.

### 9.3 Vent Parameters

This controller runs 1 or 2 vent machines independently. No additional resources – including external timers – are necessary. A brief overview of the programmable parameters for the vent machines follows:

#### **P20 -- Vent Machine Time Delay**

This setting is the length of time a pressure reading must be out of range before the controller will operate the vents. This will keep the vents from constantly cycling open, then closed. If your vents cycle too much, increase this setting using the plus (+) button. The range for this parameter is 01 to 20 seconds.

#### **P21 -- Static Pressure Differential**

The range over which the Target Pressure will be maintained. The range for this parameter is from 0.01 to 0.06 “w.c.

#### **P22 -- Tunnel Target Pressure**

In tunnel mode, this is the Target Pressure that will be maintained if and only if SWX 4 of the Tunnel Switches is ON.

#### **P25 -- Tunnel OnPoint**

This is the sensor 4 temperature at which the controller will enter tunnel mode. This is only applicable when tunneling on outside temperature.

#### **P26 -- Tunnel OffPoint**

This is the sensor 4 temperature at which the controller will exit tunnel mode. This is only applicable when tunneling on outside temperature.

### 9.4 Pressure Ramping Parameters

#### **P30 -- Ramping Mode On/Off**

Ramping mode may be turned on or off. If you choose “OFF”, you will not see the following settings. However, if you choose “ON”, with the plus or minus button, you turn ramping on, and will have to set the following items. See Section 7 on ramping for more information on this feature.

#### **P31 -- High Temperature Limit**

The outside temperature the controller will use in determining the low range of its limits.

#### **P32 -- High Temperature Target Pressure**

The target pressure when the outside temperature is at the high temperature limit.

#### **P34 -- Low Temperature Limit**

The outside temperature the controller will use in determining the high range of its limits.

#### **P35 -- Low Temperature Target Pressure**

The target pressure when the outside temperature is at the low temperature limit.

### 9.5 Pressure Alarm Parameters

#### **P60 -- Low Pressure Alarm**

The Low Pressure alarm will send a signal when pressure drops below the Low Pressure setpoint for greater than 45 seconds. This alarm warns if the

vents failed to close for some reason. Setting the Low Pressure alarm setpoint to "OFF" prevents the alarm from sounding.

#### **P61 -- High Pressure Alarm**

The High Pressure alarm will send a signal to your existing alarm system in the same manner as the Low Pressure alarm, but only when pressure exceeds the High Pressure Setpoint for greater than 45 seconds. (High Negative Pressure.) This alarm warns if the vents did not open for some reason. The Setting the alarm setpoint to 0.20 "OFF" prevents the alarm from sounding.

#### **P63 -- Cycle Pressure Alarm**

The cycle alarm is a very important alarm in that it will warn if your timer fans failed to operate. The controller will look for a pressure surge which would normally be caused when the timer fans turn on. If this pressure surge is not sensed within the timer period you specify, the controller will signal your alarm system, thus triggering an alarm. The values of P63 are from 0.00 to 0.20. Setting the value of this limit to 0.00 "OFF" prevents the alarm from sounding.

### **9.6 PC Compatible Network Parameters**

This option requires Hired-Hand's Farm Manager Software. The controller has three functions which are used to set it up on the Hired-Hand PC compatible inter-controller network (HHNet). These are:

#### **P40 -- HHNet Address**

HHNet allows you to connect up to 32 controllers on a single communications port of your personal computer (PC). In order for the computer to recognize the communications from the controllers, each controller must have a unique address. For example, if you have two Vent Master 24s, and two *Power Vents* you would need to set the first Vent Master 24 to be address 1, the second Vent Master 24 to address 2, the first *Power Vent* to address 3, and the second *Power Vent* to address 4. Valid settings are 1 - 32. (You do not have to address the controllers in any particular order.)

#### **P41 -- Version Number**

This is not settable. It is the version of controller software.

#### **P42 -- Controller Type**

This is not settable. It is a unique number that allows the network software (Farm Manager) to know the type controller.

#### **P43 -- Stage Expansion**

This Enables/Disables stages 17 through 24. Disabled = 0, Enabled = 1.

#### **P44 -- Zone Brooder Expansion**

This Enables/Disables the Zone Brooder expansion module.

### **9.7 Cool Timer Settings (ON/OFF Stages Only)**

The following two settings allow the user to set the Runtime range for their cool timer stages. These settings apply to the cool timers on the On/Off stages only. The range of these parameter is from 5 to 100 in increments of 5

#### **P70 -- Cool Timer Maximum Percentage**

This sets the maximum Runtime percentage that a cool timer stage can operate.

#### **P71 -- Cool Timer Minimum Percentage**

This sets the minimum Runtime percentage that a cool timer stage can operate.

## **9.8 Sensor Calibration**

The Vent Master 24 has four sensors that may be calibrated. The parameter(s) for calibration are PSx with x being the sensor number. The sensor temperature reading is alternately displayed along with the parameter number. You should never attempt to calibrate a sensor more than 8 degrees. If you have a setting that far out of range, it indicates that there is a problem that should be corrected.

### **PS1 -- Calibrate Sensor 1**

This reading can be changed by pressing the + or - button until the desired reading is displayed.

### **PS2 -- Calibrate Sensor 2**

This reading can be changed by pressing the + or - button until the desired reading is displayed.

### **PS3 -- Calibrate Sensor 3**

This reading can be changed by pressing the + or - button until the desired reading is displayed.

### **PS4 -- Calibrate Sensor 4**

This reading can be changed by pressing the + or - button until the desired reading is displayed.

## 10. Rarely Changed Settings

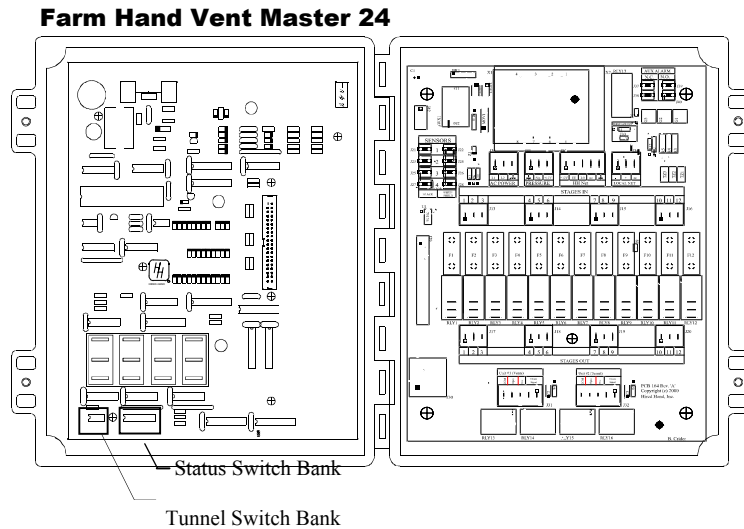

Settings which are rarely, or never, changed are found on two banks of switches located inside the front panel of the controller. The left hand bank of switches is for Tunnel Control, and the right hand bank of switches controls the status of the controller. When a switch is up it is ON, when a switch is down it is OFF. The functions of the switches are as follows:

### Tunnel Switches

#### SWX 1 - Tunnel On/Off

This switch is used to enable or disable the tunnel mode of the controller. When this switch is in the OFF position, the controller will not go into tunnel for any reason.

#### SWX 2 - Tunnel On Stage

This switch tells the controller whether it is tunneling off of the lowest programmed tunnel stage or if it is tunneling off of outside temperature. If this switch is OFF, the controller will use the “Tunnel On Point” setting for entry into tunnel.

#### SWX 4 – Split Target Pressures

If SWX 4 is OFF the Target Pressure will be used for both the Vent and Tunnel machines. If SWX 4 is ON the controller will use the Target Pressure for the Vent machine and the Tunnel Target Pressure (P22) for the Tunnel machine.

### Status Switches

#### SWX 1 - Lock

This switch is used to lock the controller. When it is on, the user may change settings such as target temperature and minimum speed/timer percentages but they can not change the settings in program mode. If the switch is set to ON the program settings are locked.

#### SWX 2 – English/Metric Units

This switch toggles between the use of English or Metric units. For English, the temperatures are displayed in Fahrenheit and the pressure is displayed in inches of water column (“ w.c.”). For Metric units, the temperature is displayed in Celsius and the pressure is displayed in Pascals or millimeters of water (mm H<sub>2</sub>O) depending on the setting of SWX 6. (Note: If SWX 2 is changed, you will have to reset your tunnel on points and OffPoints and your target temperature.)

**SWX 3 - 5/10 minute timer**

This switch selects between a 5 and 10 minute system timer. If the switch is ON, the timer is 10 minutes.

**SWX 4 - Sensor 3 Active**

This switch turns off sensor 3. If the switch is off, sensor 3 is turned off.  
 Note: This is used to disable the sensor in the back half of a half house brooding situation. This way the low temperature reading does not affect the temperature readings for the rest of the house. Just be sure that Sensor 3 is placed in the non-brood end of the house. If the switch is ON, sensor 3 is used.

**SWX 5 – Split Vent Units**

If SWX 5 is ON, PowerTrak #1 will control the Vents and PowerTrak #2 will control the Tunnel mode. If SWX 5 is OFF, PowerTrak #1 and PowerTrak #2 will always work together to maintain static pressure.

**SWX 6 - Pascals/mm H<sub>2</sub>O**

If SWX 2 is set for Metric units, and SWX 6 is set to ON, pressure is displayed in millimeters of water (mm H<sub>2</sub>O). If SWX 6 is set to OFF, the pressure is displayed in Pascals.

**SWX 7 – Initialize Defaults**

This switch is not implemented and must remain in the OFF position.

**SWX 8 - Program 'A' or 'B'**

This switch is used to toggle between 2 preset programs. This could be used to store separate summer/winter programs for instance. The ON position is for Program A, and the OFF position is for Program B.

## 11. Controller Installation and Setup

### Tools Required

Mini Screwdriver	Standard Screwdriver
Wire Strippers	

### Installation Instructions

- Unpack system, and check that all components are present.
  - Farm Hand Vent Master 24
  - Installation Kit
  - Fuse Kit
  - Sensors
  - Static Pressure Monitor
  - Manual
- Hang Farm Hand Vent Master 24 with four screws.
- Make sure all power supplies are disconnected before breaking any wires, or reaching into the enclosure.
- Open the Vent Master 24 and find all connections. Refer to wiring diagrams in back of this manual.
- Run sensors out to locations inside the house. (Outside sensor should be installed outside the house.) Be sure that the sensors are in a safe location, free from any temperature influences (direct sunlight, water, etc.) Use care when securing sensor wires so that you do not cut the wire. Any short, or break in the wire will cause improper sensor operation.



6. Connect each sensor to its appropriate terminals inside the enclosure. (See wiring diagrams in the back of this manual.)
7. Connect wires from stage terminals to the contactor panel, or relay box. See wiring diagrams for locations of terminals.
8. Hookup three wire connections from Vent Master 24 board to the vent machines. See wiring diagrams for locations of terminals.
9. Connect the remote pressure unit.
10. **CHECK THE POSITION OF THE VOLTAGE SELECTOR SWITCH.**  
Connect the wires for 120/240V power to the terminals specified in the wiring diagram.

## 12. Programming Examples

When following these examples, you will need to refer to the Program Reference section to see which options are available for each of the parameters (P1, P24, etc.).

### 12.1 Setting Stage OnPoints and OffPoints

OnPoint and OffPoint are easily set by pressing the numbered button on the left hand side of the front panel. When you press one of the stage buttons, the main display will show "ON". Then use the + and - buttons until you see your setting in the individual stage display. (The stage display you are adjusting will flash until you press the stage button again.) If you want to program all the stages OnPoints, you may do so by clicking on another stage's button, then using the + and - buttons.

Press the stage button again, and the main display will show "OFF" adjust the OffPoint just like you did the on point. When you are finished, press the stage button again, and you will return to normal operation. Repeat this process for each of the twelve stages.

### 12.2 Setting up Stage Modes, and Timer Status

There are three parameters used in programming any stage. They are P1-P3. The following is an overview of how to program a stage:

1. Enter *Program Mode* by pressing and holding the *Mode* button for 5 seconds until **P1** is displayed, and the stage 1 display begins to flash. This parameter selects the sensor(s) that this stage watches for on/off operation.
2. Select the stage you want to program by pressing the stage button (next to the stage display.)
3. Press the + or - button until the desired sensor is displayed. 100= sensor 1; 020 = sensor 2; 120 = Average of Sensors 1& 2; 003 = Sensor 3; 103 = Average of Sensors 1 & 3; 023 = Average of Sensors 2 & 3; 123 = Average of Sensors 1,2,& 3. If you want to program more stages sensors, press the next stage's button, and repeat step 3.
4. Press the *Mode* button again and **P2** is shown. This parameter selects what mode the stage operates as.
5. Press the + or - button until the desired mode is displayed.
6. If you want to program more stages modes, press the next stage's button, and repeat step 6.
7. Press the *Mode* button until **P3** is displayed. This parameter allows you to put a stage on the system timer (5 or 10 minutes).
8. Press the + or - button until the desired setting is displayed.
9. If you want to program more stages stage timer settings, press the next stage's button, and repeat step 9.

10. Exit Program Mode by pressing the *Mode* button until after **PS4** has been displayed or wait 1 minute.

### 12.3 **Setting Up Tunnel Control**

**Note:** If you do not want the controller to ever enter tunnel mode just make sure that the Tunnel On/Off switch is in the off position and you can ignore this section.

The Vent Master 24 is a very versatile tunnel controller. It provides the grower with many different ways to tunnel based on the layout of the house. It also provides two different ways of initiating tunnel mode. The following are some tips and examples of setting up this controller to tunnel your house appropriately.

1. The first step in setting up your tunnel house is to configure the stages that you want as your **cool tunnel stages**. If some stages need to operate in tunnel mode and in normal mode, then program these stages to be **cool negative tunnel stages**. See the Program Reference section in the back of this manual for more information on the operation of various stage modes.
2. The next step is to determine if you would like to operate your building at a different static pressure while in tunnel. If so, you must set the Split Target switch (Tunnel Switch SWX 4) to ON. Then set the desired tunnel pressure with P22.
3. The last step in setting up your tunnel house is determining how you would like to initiate tunnel mode. You can initiate tunnel mode by outside temperature or by your lowest programmed **cool tunnel stage**. The lowest programmed cool tunnel stage is determined by the lowest OnPoint. If you would like to tunnel based on outside temperature you must set the **Tunnel On Stage** (SWX-2) switch to off. You can then set the temperature at which you would like to enter tunnel mode at **P25** and the temperature at which you would like to exit tunnel mode at **P26**. Otherwise, set the **Tunnel On Stage** (SWX-2) to ON.

### 12.4 **Cool Timer Stage Operation**

On the Farm Hand Vent Master 24 any of the ON/OFF can be placed on a cool timer. A cool timer stage will come on and run at the timer percentage whenever temperature is above it's OffPoint (**Off**), and its timer percentage will increase as temperature rises. The following graph shows how you can vary this percentage.

Refer to Graph 1 and Table 1. The stage is placed on a cool timer by setting **P3=2**. A Cool Timer stage always varies its runtime based on the stage's temperature and its **ON** and **OFF** settings. In this example, the OffPoint is set to 80°F (**OFF=80**), and the OnPoint is set to 86°F (**ON=86**). **The stage will not run if the temperature is below the OffPoint, as shown in Graph 1.** When the temperature reaches the OffPoint, the stage is placed on the system timer.

To enhance temperature control, the Runtime percentage of a cool timer stage can be varied. The percentage of the Runtime that the cool timer stage is ON can be varied when the temperature is between the OffPoint and the OnPoint by setting parameters P70 and P71. In this example, the Minimum Runtime percentage is 50%, as set by **P71 = 50**. The Maximum Runtime percentage is 90%, as set by **P70 = 90**.

When the temperature reaches 80° F the stage runs for 50% of the Runtime period (2-1/2 minutes if the system timer is set for 5 minutes, or 5 minutes if the system timer is set for 10 minutes). As the temperature increases, the Runtime percentage of the stage progressively increases up to the Maximum Runtime percentage of 90% when the temperature reaches 86° F. Above 86°F, the Runtime percentage remains constant at 90%.

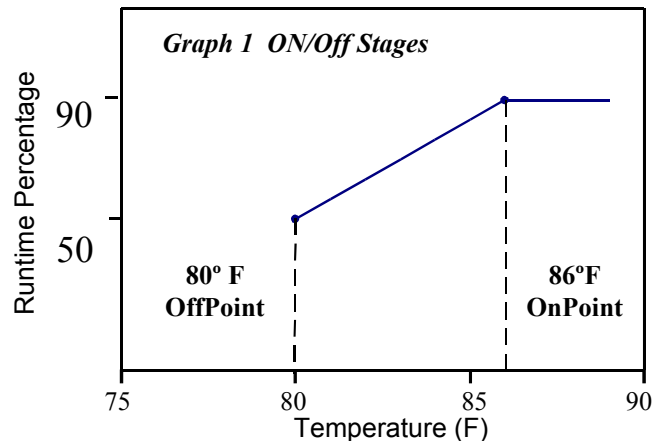

**Table 1 Example Of Cool Timer Stage Operation**

Setting	Stage Sensor	Stage Mode	Stage Timer	OffPoint	OnPoint	Cool Timer Max %	Cool Timer Min %
Parameter	P1	P2	P3	OFF	ON	P70	P71
Value	10	02	02	80	86	90	50
Option	Sensor 1	Cool Stir	Timer ON	Minimum OnPoint	Maximum OnPoint	Maximum Runtime %	Minimum Runtime %

**Brief Description Of Cool Timer Stage Operation**

As you can see, a stage will be placed on the system timer once the temperature rises above 80°F (OFF) and will start running 50% (P71) of the time. If the temperature continues to increase then the run time percentage will also increase toward 90% (P70).

### 13. Maintenance

Check the calibration of your sensors at least once per quarter. You will need to have two people: one person at the sensor with a trusted thermometer, and one at the controller to set the sensor to the proper setting.

### 14. Wiring Diagrams, Schematics, etc.

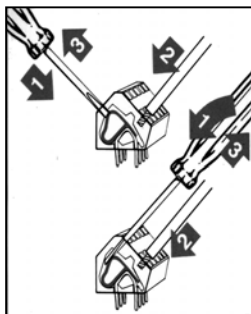

All wiring connections for stages, vent machines, variable speed fans, and curtain sensors inside the controller are made without terminals on the end of the wire. To make the connection, strip about 1/4" of the insulation off the wire, and follow the diagram below.

1. Insert a small screwdriver into either the hole shown in the diagram.
2. Insert the stripped end of the wire into the hole shown in the diagram.
3. Remove the screwdriver, and tug slightly on the wire to check that it is snug.

## Warning!

Do not connect more than 12 amps of load to any one stage. The Variable Speed Circuit will carry up to 12 amps.

115/230 V Selector Switch

# FARM HAND VENT MASTER

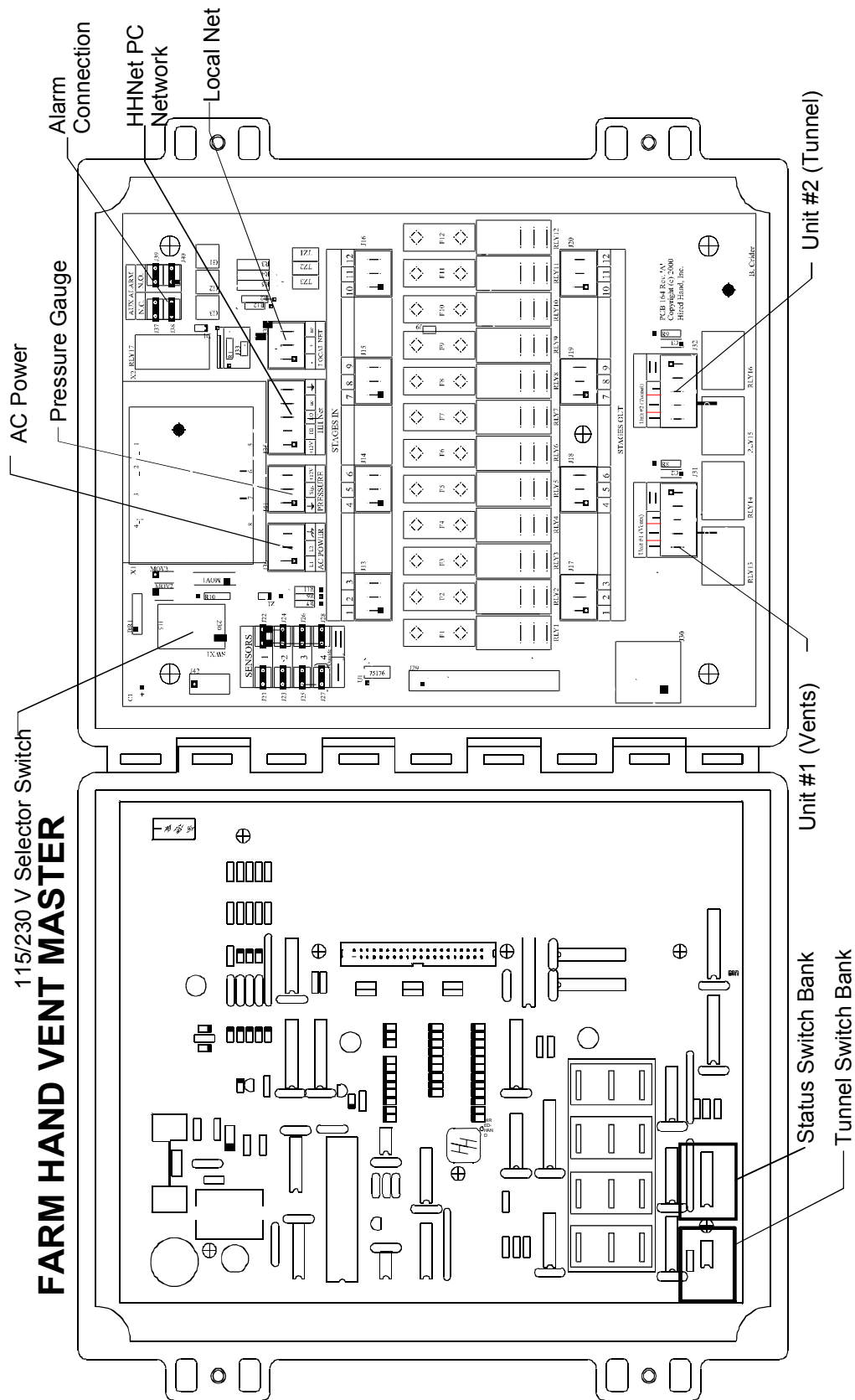

## 14.1 Connecting the Vent Machines to the Vent Master 24

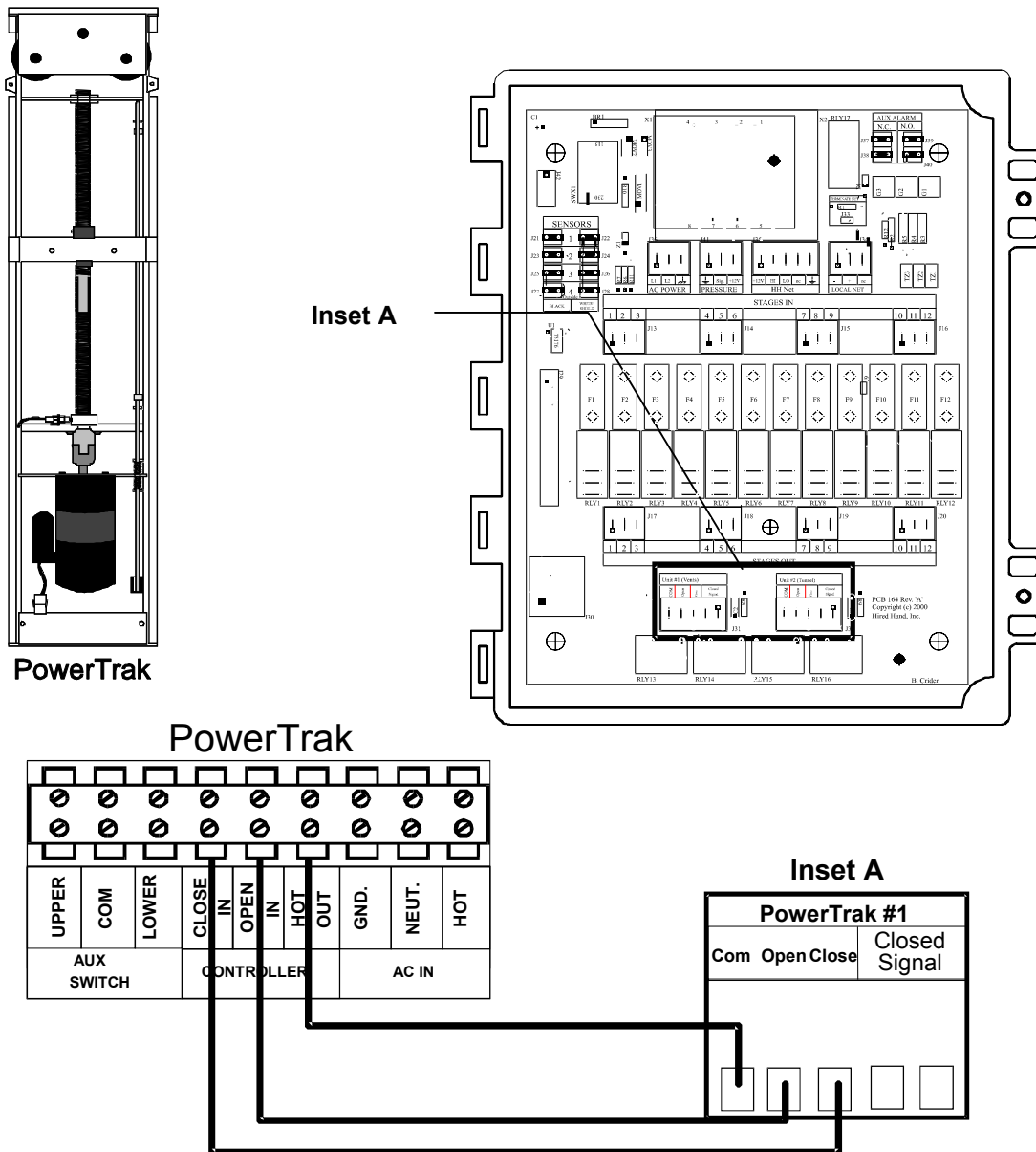

**Note:** If you are tunneling with this controller, the tunnel inlets must be connected to "PowerTrak #2". The vent inlets should be connected to "PowerTrak #1"

**Note:** Only 1 PowerTrak can be connected to each PowerTrak outlet. If additional PowerTraks are needed, the use of relay boxes are necessary to separate the load.

## 14.2 Connecting an SCS™ Panel to the Vent Master 24

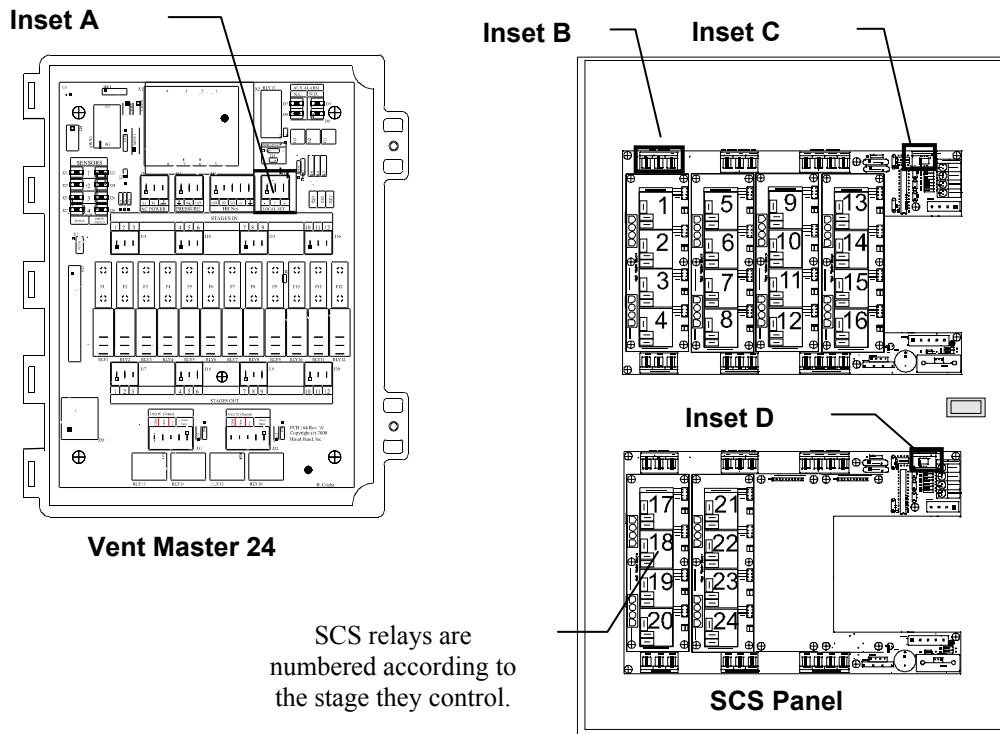

### Connecting the Local Network Cable

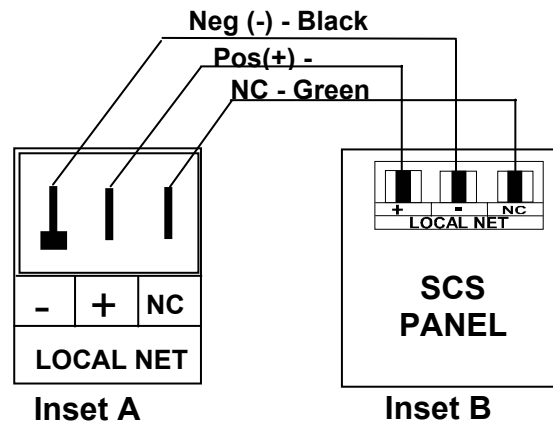

### Setting the Local Network Address

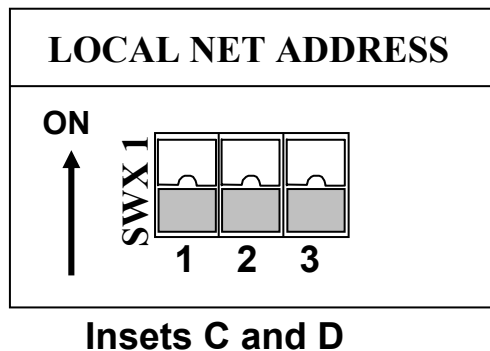

NOTE: Address switch settings must be set to ON,ON,ON for both the SCS 16 and the SCS 8 stage panels when connected to the Vent Master 24.

### 14.3 Connecting Sensors to the Vent Master 24

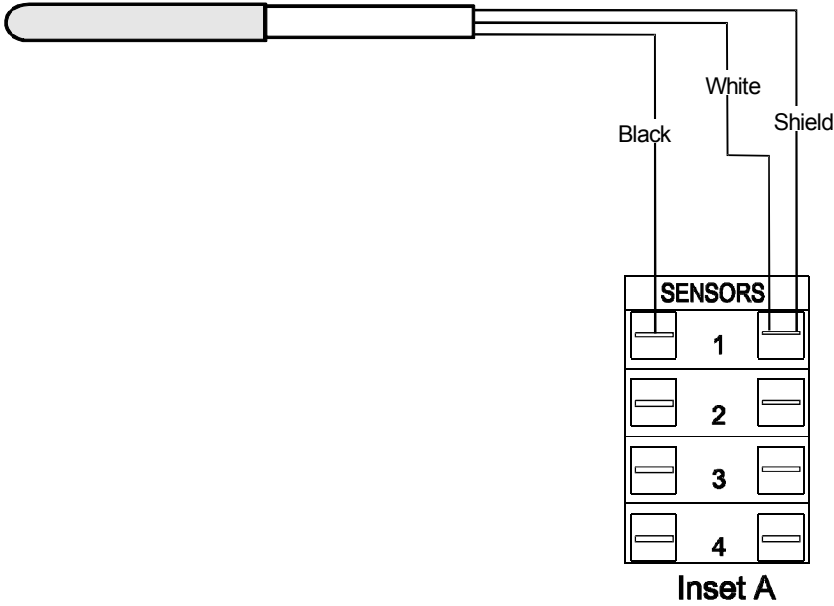
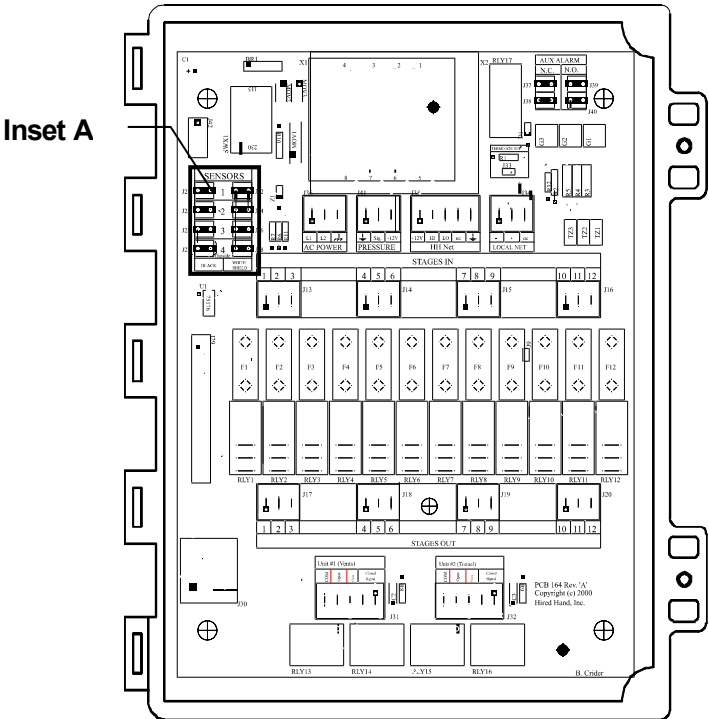

The controller has a switch for disabling Sensor 3. If you use a half house brood layout, you need to place Sensor 3 in the non brood section of the house, and disable Sensor 3 by turning switch 4 of the Status Switch Bank to off. (See “Rarely Changed Settings” for more information.)

### 14.4 Connecting AC Power to the Vent Master 24

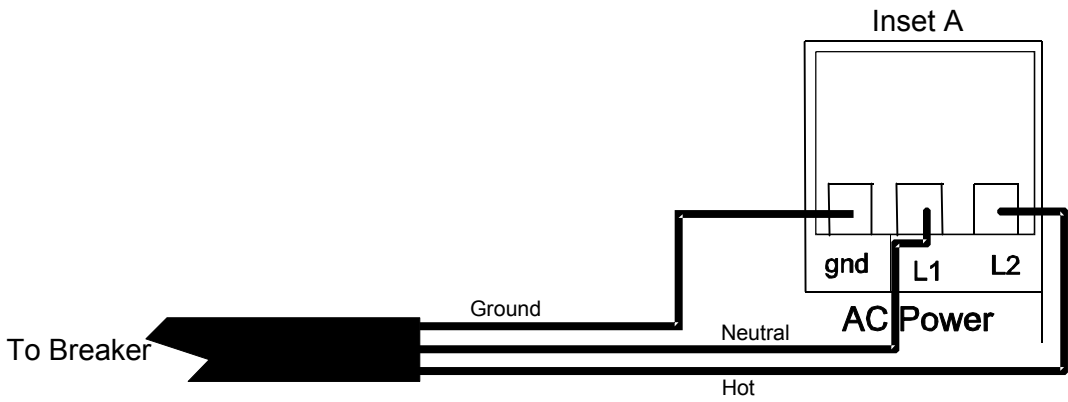
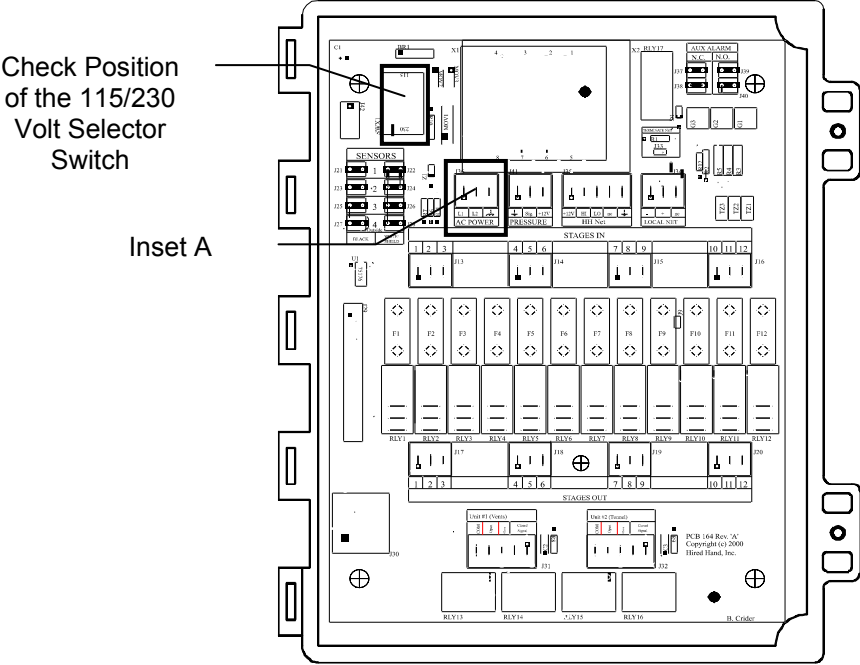



## 14.5 Connecting the Vent Master 24 to a Data Shuttle

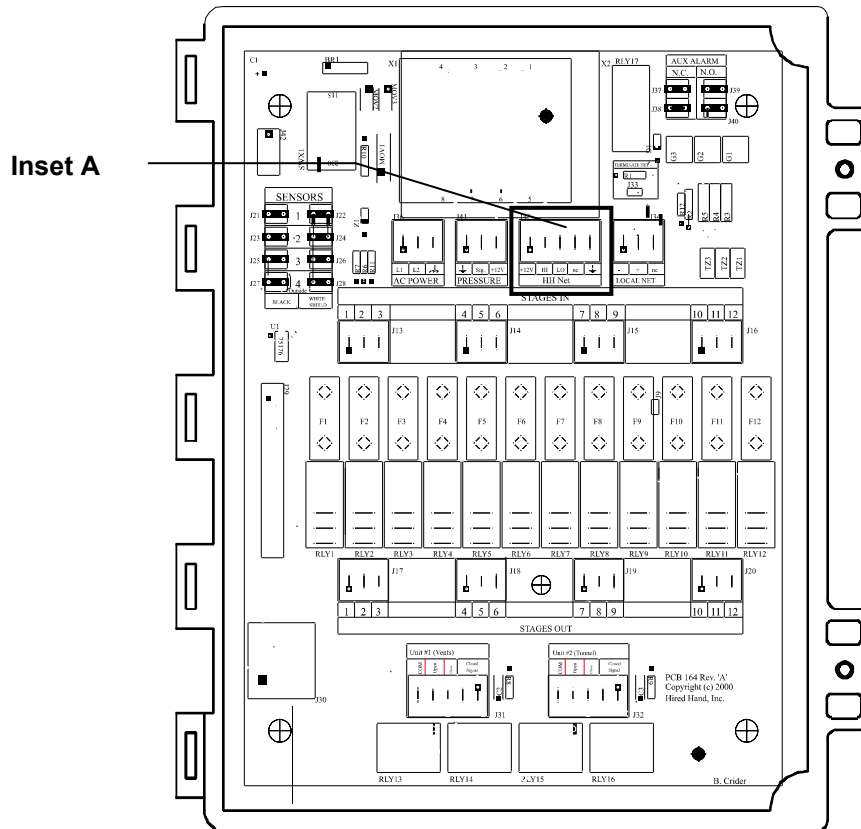

**Inset A**

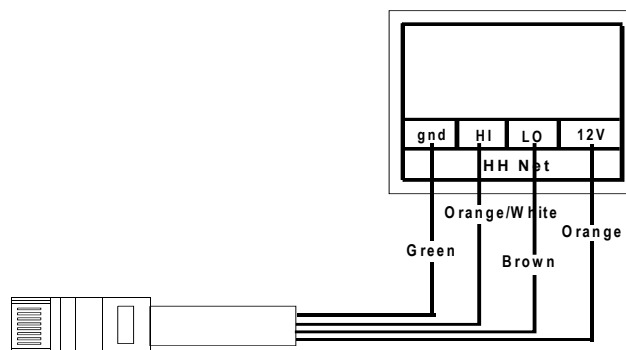

### 14.6 Connecting the Vent Master 24 to a Static Pressure Monitor

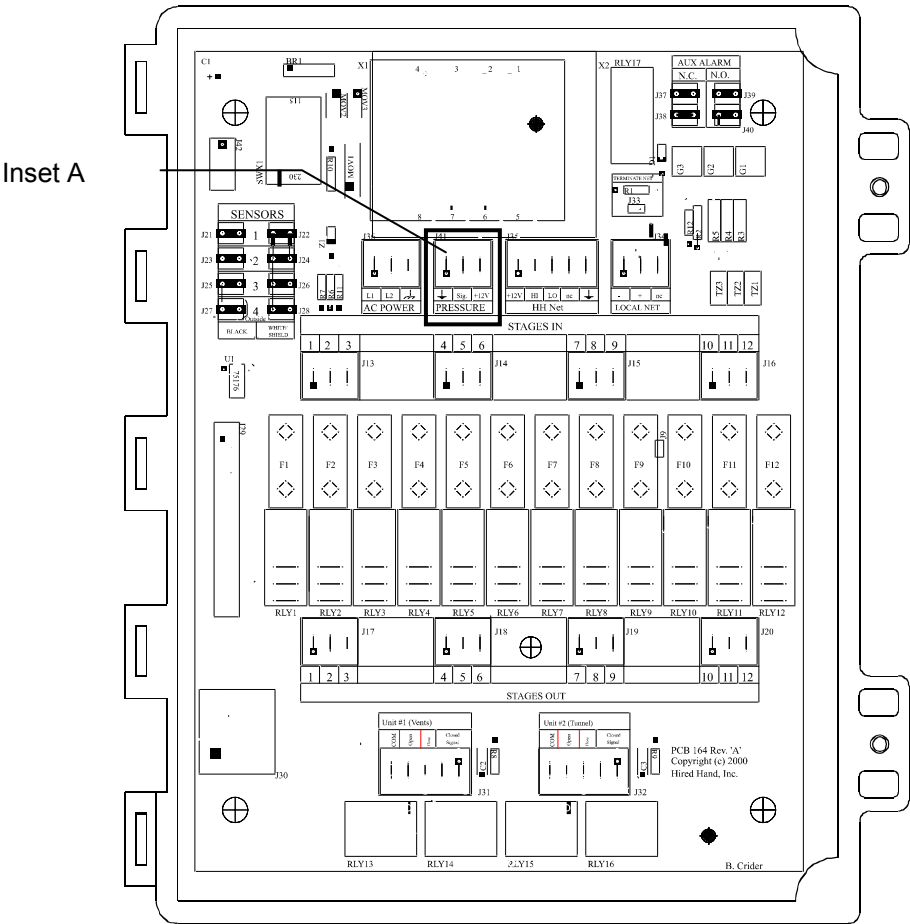

Static Pressure Monitor

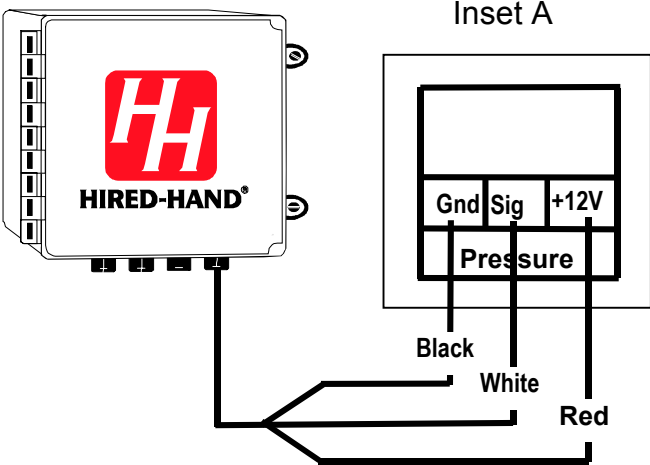

## 14.7 Connecting the Vent Master 24 to a Series or Parallel Alarm

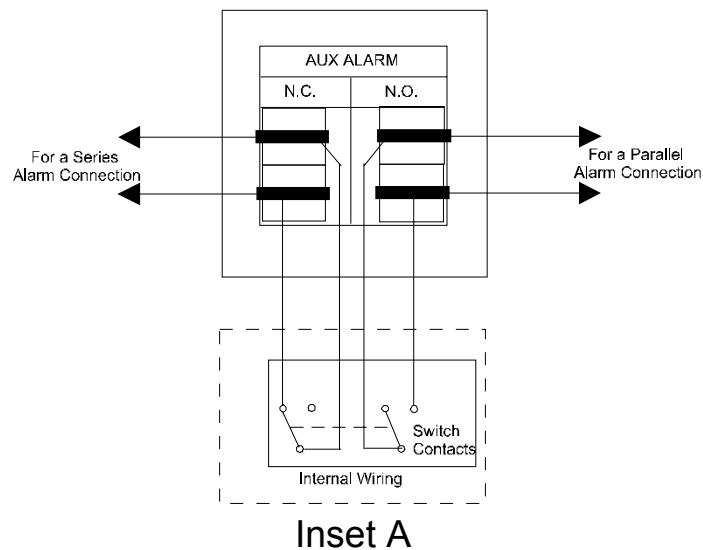
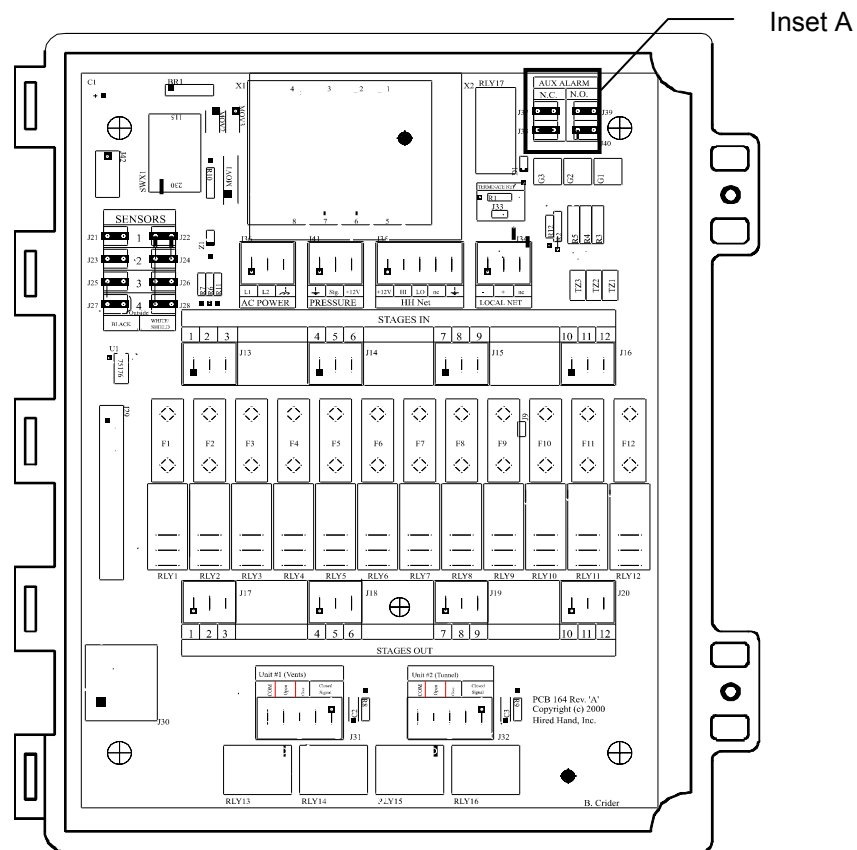

**Note: The internal wiring shows the condition of the alarm relay during normal conditions (no alarm present). During an alarm condition, the contact positions will be reversed.**

## 15. Program Reference

### Program Parameters

#### PSd --Room Temp Display

Default reading displayed in the Main Display.

- 100 = Sensor 1
- 020 = Sensor 2
- 120 = Average of Sensors 1 & 2
- 003 = Sensor 3
- 103 = Average of Sensors 1 & 3
- 023 = Average of Sensors 2 & 3
- 123 = Average of Sensors 1,2 & 3

#### P1 -- Stage Sensors (Stages 1-12 & 13-24)

The combination of sensors used to determine whether that stage should be on or off.

- 100 = Stage uses sensor 1
- 020 = Stage uses sensor 2
- 120 = Average of sensors 1 & 2
- 003 = Stage uses sensor 3
- 103 = Average of sensors 2 & 3
- 023 = Average of sensors 2 & 3
- 123 = Average of sensors 1,2 & 3

#### P2 -- Stage Mode (Stages 1-12 & 13-24)

Heat, Cool Negative, etc. This setting determines when the stage is allowed to run, and how the stage will run.

- 1 = Heat Mode
- 2 = Cool Stir Mode
- 3 = Cool Negative Mode
- 4 = Cool Negative Tunnel Mode
- 5 = Cool Tunnel Mode

#### P3 -- Stage on Timer (Stages 1-12 & 13-24)

Any cool stage can be placed on the system timer. This timer is settable to 5 or 10 minutes. Any stage on a timer will run for the system runtime percentage. (Example: 30% runtime of 10 minutes = 3 minutes out of each ten minutes.)

- 0 = No Timer
- 1 = Standard Timer
- 2 = Cool Timer

#### ON -- OnPoint

The temperature at which a stage will turn on.

#### OFF -- OffPoint

The temperature at which a stage will turn off.

#### P10 -- Minimum Runtime Percentage

If temperature is below the target, the percent of the system timer that the fan will run at its minimum speed.

#### P11 -- Motor Curve

Different manufacturers motors speeds vary at different rates. For this reason, it is necessary to make calculations based on the fan manufacturer. 0 = Hired-Hand

#### P20 -- Vent Machine Time Delay

This setting is the length of time a pressure reading must be out of range before the controller will operate the vents. This will keep the vents from constantly cycling open, then closed. If your vents cycle too much, increase this setting using the plus (+) button.

#### P21 -- Static Pressure Differential

The range over which the Target Pressure will be maintained.

<b>P22 -- Tunnel Target Pressure</b>	In tunnel mode, this is the Target Pressure that will be maintained if and only if SWX 4 of the Tunnel Switches is ON.
<b>P25 – Tunnel OnPoint</b>	The temperature at which the controller will go into tunnel mode.
<b>P26 -- Tunnel OffPoint</b>	The temperature at which the controller will go out of tunnel mode.
<b>P30 – Ramping Mode On/Off</b>	Ramping mode may be turned on or off. If you choose an “OFF”, you will not see settings P31 through P35. However, if you choose an “ON” with the plus or minus button, you turn ramping on, and will have to set the following items. See Section 7 on ramping for more information about this feature.
<b>P31 – High Temperature Limit</b>	The outside temperature the controller will use in determining the low range of its limits.
<b>P32 – High Temperature – Target Pressure</b>	The upper limit for pressure when outside temperature is at the high temperature limit.
<b>P34 – Low Temperature Target Pressure</b>	The outside temperature the controller will use in determining the high range of its limits.
<b>P35 – Low Temperature – High Pressure Setpoint</b>	The upper limit for pressure when outside temperature is at the low temperature limit.
<b>P40 - HHNet Address</b>	Unique setting for controllers along a single network wire pair. Only used with the PC compatibility feature using Hired-Hand’s Farm Manager software.
<b>P41 -- Version Number</b>	This is the version of the code for the controller. This value is not settable.
<b>P42 -- Controller Type</b>	This is a number that identifies the type of controller (Vent Master 24) to the Farm Manager Software (PC compatible)
<b>P43 -- Stage Expansion</b>	This Enables/Disables stages 17 through 24. Disabled = 0, Enabled = 1.
<b>P44 – Zone Brooder Expansion</b>	This Enables/Disables the Zone Brooder expansion module.
<b>P60 – Low Pressure Alarm</b>	The Low Pressure alarm will send a signal when pressure drops below the low pressure setpoint for greater than 45 seconds. This alarm warns if the vents failed to close for some reason. Setting the Low Pressure alarm setpoint to 0 (zero) prevents the alarm from sounding.
<b>P61 – High Pressure Alarm</b>	The High Pressure alarm will send a signal to your existing alarm system in the same manner as the High Pressure alarm, but only when pressure exceeds the High Pressure Setpoint for greater than 45 seconds. (High Negative Pressure.) This alarm warns if the vents did not open for some reason. Setting the alarm setpoint to 0.20 prevents the alarm from sounding.
<b>P63 – Cycle Pressure Alarm</b>	The cycle alarm is a very important alarm in that it will warn if your timer fans failed to operate. The controller will look for a

pressure surge that would normally be caused when the timer fans turn on. If this pressure surge is not sensed within the timer period you specify, the controller will signal your alarm system, thus triggering an alarm. The setting is for time in minutes, and setting the value of this limit to 0 (zero) prevents the alarm from sounding.

**P70 = Cool Timer  
Maximum  
Percentage**

This sets the maximum Runtime percentage that a cool timer stage can operate.

**P71 = Cool Timer  
Minimum  
Percentage**

This sets the minimum Runtime percentage that a cool timer stage can operate.

**PS1 - Calibrate Sensor 1**

The temperature the controller reads from the sensor. This setting is used only when calibrating sensors. Press the + and/or - buttons until the correct reading is seen in the main display. (See Sensor Calibration)

**PS2 -- Calibrate Sensor 2**

Same instructions as sensor PS1

**PS3 -- Calibrate Sensor 3**

Same instructions as sensor PS1

**PS4 -- Calibrate Sensor 4**

Same instructions as sensor PS1

## **Tunnel Switches (Located inside the Controller Door)**

**SWX 1 - Tunnel On/Off**

Enables/Disables tunnel mode. When this switch is in the OFF position, the controller will not go into tunnel for any reason.

**SWX 2 - Tunnel On Stage**

Option to have the controller go into tunnel whenever the first tunnel stage turns on. If this switch is OFF, the controller will use the "Tunnel OnPoint" setting for entry into tunnel.

**SWX 4 – Split Target  
Pressures**

If SWX 4 is OFF the Target Pressure will be used for both the Vent and Tunnel machines. If SWX 4 is ON the controller will use the Target Pressure for the Vent machine and the Tunnel Target Pressure (P22) for the Tunnel machine.

## **Status Switches (Located inside the Controller Door)**

**SWX 1 - Lock**

Locks the front panel to protect your settings from accidental change. If the switch is set to ON the program settings are locked.

**SWX 2 - English/Metric  
Units**

This switch toggles between the use of English or Metric units. For English, the temperatures are displayed in Fahrenheit and the pressure is displayed in inches of water column (" w.c."). For Metric units, the temperature is displayed in Celsius and the pressure is displayed in Pascals or millimeters of water (mm H<sub>2</sub>O) depending on the setting of SWX 6. (Note: If SWX 2 is changed, you will have to reset your tunnel OnPoints and OffPoints and your Target Temperature.)

- SWX 3 - 5/10 minute timer** This switch selects between a 5 and 10 minute system timer. If the switch is on, the timer is 10 minutes.
- SWX 4 - Sensor 3 Active** When this switch is in the off position, Sensor 3 is turned off. Note: For half house brooding, place Sensor 3 in the non-brooding end of the house, and disable it with this switch when brooding. If the switch is ON, sensor 3 is used.
- SWX 5 - Split Vent Units.** If SWX 5 is ON, PowerTrak #1 will control the Vents and PowerTrak #2 will control the Tunnel mode. If SWX 5 is OFF, PowerTrak #1 and PowerTrak #2 will always work together to maintain static pressure.
- SWX 6 - Pascals/mm H<sub>2</sub>O** If SWX 2 is set for Metric units, and SWX 6 is set to OFF pressure is displayed in Pascals. If SWX 6 is set to ON, the pressure is displayed in millimeters of water (mm H<sub>2</sub>O).
- SWX 7 – Initialize Defaults** This switch is not implemented and must remain in the OFF position.
- SWX 8 - Program ‘A’ or ‘B’** This switch is used to toggle between 2 preset programs. This could be used to store separate summer/winter programs for instance.

## 16. Error Codes

### 16.1 Descriptions

If your controller is displaying an “E1”, or “E2”, etc. the controller has recorded an error. The controller records errors from sensor readings, and tunnel related problems. To diagnose your controller problem, look up the error on the table (under “Error Codes”) and look across the table to find the components that have failed. (Items with an “x” have failed according to the controller.)

Error Code	Description	Sensor 1 Error	Sensor 2 Error	Sensor 3 Error	Sensor 4 Error	Pressure Error
E1	Sensor 1 Error	X				
E2	Sensor 2 Error		X			
E3	Sensor 1 & 2 Error	X	X			
E4	Sensor 3 Error			X		
E5	Sensor 1 & 3 Error	X		X		
E6	Sensor 2 & 3 Error		X	X		
E7	Sensor 1,2 & 3 Error	X	X	X		
E8	Sensor 4 Error				X	
E9	Sensor 1 & 4 Error	X			X	
E10	Sensor 2 & 4 Error		X		X	
E11	Sensor 1,2 & 4 Error	X	X		X	
E12	Sensor 3 & 4 Error			X	X	
E13	Sensor 1,3 & 4 Error	X		X	X	
E14	Sensor 2,3 & 4 Error		X	X	X	
E15	All Sensor Error	X	X	X	X	
E32	Static Pressure Cycle Error					X
E64	High Static Pressure Error					X
E128	Low Static Pressure Error					X

**Note: There are other error codes that are possible since there are too many possibilities to list. Any error codes that are encountered other than the ones listed above should be reported to Hired Hand to determine the cause of the error.**

## 16.2 Local Network Overview of Control System Devices

The following will overview all of the devices in this control system. It will also explain the local network tools that are employed by each device.

### Farm Hand Vent Master 24

The **Vent Master 24** is the heart and soul of this control system. It makes most all of the decisions and sends commands out over the **Local Net**. If problems occur with the **Local Net**, the **Vent Master 24** will indicate the problems using local network codes (**LN##**). These codes indicate which modules are not responding to commands over the local network. This table is very important when trying to trouble-shoot the system.

Vent Master 24 Local Network Errors

Error Code	SCS 16	SCS 8	SCS Back-Up	FH Heat Zone
1	X			
2		X		
3	X	X		
4			X	
5	X		X	
6		X	X	
7	X	X	X	
8				X
9	X			X
10		X		X
11	X	X		X
12			X	X
13	X		X	X
14		X	X	X
15	X	X	X	X

### SCS Back-Up System

The **SCS Back-Up System** is a vital member of this control system. It has two roles: 1. Monitor the communication over the local network. 2. Control the environment using its temperature sensor(s) and its four stages. It is important to note that this **Back-Up System** is a stand-alone controller that has the ability to control the same drive relays that the **Vent Master 24** is controlling. Therefore, if the temperature is outside its **High** or **Low** limits it will operate the appropriate stages no matter what is happening with the local network.



In addition, it can monitor the network to provide two other functions for emergency situations. These other two functions do not have any effect on its primary job of monitoring the High and Low limits. These functions are indicated with local network error codes (LN##). The following shows the two error codes and explains how the **Back-Up System** functions during these situations. These are very important functions to note because they can cause confusion but they are important functions of the **Back-Up System**.

- **LNE – Local Network Error**

LNE indicates that the **Back-Up System** is unable to communicate with the **Vent Master 24**. Therefore, the **Back-Up System** assumes that it is unable to communicate with the **SCS Relay Modules** also. This triggers a very important function. The **Back-Up System** will begin running its first stage of cooling (**Cool1**) on a back-up timer to maintain minimum ventilation. It is also important to note that the **Alarm Relay** on the **Back-Up System** will be triggered.

- **LNO – Local Network Override**

LNO indicates that the **Back-Up System** is communicating with the **Vent Master 24** but the **Vent Master 24** is unable to communicate with 1 or more of the **SCS Relay Modules**. This triggers the second important function. Since the **Vent Master 24** is unable to control the stages through its normal means. It will attempt to maintain the environment through the **Back-Up Systems** output stages. Therefore, if the **Vent Master 24** is attempting to turn on **Cool Negative** stages over the local network but can not, it will command the **Back-Up System** to turn on **Cool1**. Or, if the **Vent Master 24** was trying to turn on a **Heat** stage it would command the **Back-Up System** to turn on **Heat**. Refer to the SCS manual for a more detailed description of the **Back-Up Systems** functions during the LNO condition. Again, it is important to note that this does not impede the **Back-Up System** from doing its primary job of monitoring the temperature against its **High** and **Low** Limits.

### **SCS-16 Relay Module and SCS-8 Expansion Relay Module**

The **SCS-16** and **SCS-8** will be included in the same section because their error indicators are identical. The function of these modules is to accept commands from the **Vent Master 24** as to which drive relays should be on. These devices communicate only with the **Vent Master 24**. They do not communicate with the **Back-Up System**. The **Back-Up System** is connected to the relay cards on these modules through hard wiring. This is important to note because the **Back-Up System** does not require the Local Net to be operating to override the drive relays during an emergency back-up condition.

These modules contain LED indicators located in the top right hand corner of the board. These indicators are tools to be used when trouble-shooting these modules. The following list these indicators and explains their function.

- **Power LED**

This LED indicates that power is supplied to the board.

- **Normal LED**

This LED indicates the internal operation of the module. It is similar to the **LNE** on the **Back-Up System**. It can indicate two functions as described below:

1. **On Continuously**

In this condition, the module is receiving commands from the **Vent Master 24** and the data is determined to be correct.

2. **Flashing**

In this condition, the module is **not** receiving data from the **Vent Master 24** or the data is determined to be incorrect. At this time, the

SCS module will shut down its stages and allow the **Back-Up System** to control the drive relays.

- **Receive LED**

This LED is used to indicate incoming network traffic. It doesn't necessarily indicate that the incoming data is intended for this module or that the incoming data is correct. It just means that data is being passed across the network.

- **Transmit LED**

This LED is used to indicate outgoing network traffic. Therefore, if the LED is flashing it indicates that good data has been received by the module and an acknowledgment has been transmitted.

**Important: Note the red and white piano switch in the top right hand corner of the board near the LED indicators. This is an address switch. It will be used in the future on controller upgrades. But, when used with the Vent Master 24, the switches have to be in the "ON" position.**

## 16.3 Possible Solutions

### Sensor Error

If any of the sensors are bad try the following:

- Reset the controller by taking power away at the breaker, or unplugging it.
- Determine which sensor is bad, then check the connection inside the controller door. If the error is for sensor 3, read the section below to determine alternate course of action.
- Determine which sensor is bad, then check the sensor that is hanging in the house to make sure that it has not been damaged.
- Replace the bad sensor.

### Sensor 3 Error

- Check to see if you are using sensor 3. If not, deactivate it using switch number 4 (SWX-4) on the status switch bank located on the back of the controller's door.

### Cycle Error

- If a Cycle error has occurred, it will flash the error code until the error is manually reset by removing power from the controller and then reapplying power.
- If a Cycle error is indicated, check the operation of the timer fan.
- Also, check the operation of the inlets.

### High Pressure Error

- If a High Pressure error has occurred, it will flash the error code until the error is manually reset.
- If a High Pressure error is indicated, check the operation of the inlets.

### Low Pressure Error

- If a Low Pressure error has occurred, it will flash the error code until the error is manually reset.
- If a Low Pressure error is indicated, check the operation of the fans and inlets.

## 16.4 Temperature vs. Sensor Resistance Table

The following chart gives the resistance when measured between the white and black sensor wires at a given temperature. To check a sensor, first know the temperature in the area, then, use a multi-meter to check the resistance.

Resistance Kohms	Temp (F)	Temp (C)	Resistance Kohms	Temp (F)	Temp (C)	Resistance Kohms	Temp (F)	Temp (C)
32.654	32	0	15.714	59	15	8.59	83.3	28.5
32.158	32.5	0.3	15.568	59.4	15.2	8.517	83.7	28.7
31.671	33.1	0.6	15.353	59.9	15.5	8.408	84	28.9
31.191	33.6	0.9	15.211	60.3	15.7	8.336	84.6	29.2
30.72	34.2	1.2	15.001	60.8	16	8.23	85.1	29.5
30.257	34.7	1.5	14.863	61.2	16.2	8.125	85.6	29.8
29.802	35.2	1.8	14.658	61.7	16.5	8.056	86	30
29.355	35.8	2.1	14.457	62.2	16.8	7.954	86.5	30.3
28.915	36.3	2.4	14.325	62.6	17	7.853	87.1	30.6
28.482	36.9	2.7	14.128	63.1	17.3	7.787	87.4	30.8
28.057	37.4	3	13.999	63.5	17.5	7.689	88	31.1
27.777	37.8	3.2	13.808	64	17.8	7.592	88.5	31.4
27.363	38.3	3.5	13.682	64.4	18	7.496	89.1	31.7
26.957	38.8	3.8	13.496	64.9	18.3	7.433	89.4	31.9
26.557	39.4	4.1	13.373	65.3	18.5	7.34	90	32.2
26.164	39.9	4.4	13.192	65.8	18.8	7.248	90.5	32.5
25.777	40.5	4.7	13.073	66.2	19	7.157	91	32.8
25.523	40.8	4.9	12.896	66.7	19.3	7.098	91.4	33
25.147	41.4	5.2	12.779	67.1	19.5	7.009	91.9	33.3
24.777	41.9	5.5	12.607	67.6	19.8	6.922	92.5	33.6
24.413	42.4	5.8	12.493	68	20	6.836	93	33.9
24.055	43	6.1	12.325	68.5	20.3	6.779	93.4	34.1
23.82	43.3	6.3	12.215	68.9	20.5	6.695	93.9	34.4
23.472	43.9	6.6	12.051	69.4	20.8	6.612	94.5	34.7
23.13	44.4	6.9	11.943	69.8	21	6.531	95	35
22.793	45	7.2	11.783	70.3	21.3	6.45	95.5	35.3
22.572	45.3	7.4	11.678	70.7	21.5	6.371	96.1	35.6
22.244	45.9	7.7	11.522	71.2	21.8	6.319	96.4	35.8
21.922	46.4	8	11.42	71.6	22	6.241	97	36.1
21.71	46.8	8.2	11.268	72.1	22.3	6.165	97.5	36.4
21.397	47.3	8.5	11.168	72.5	22.5	6.089	98.1	36.7
21.088	47.8	8.8	11.02	73	22.8	6.015	98.6	37
20.886	48.2	9	10.874	73.6	23.1	5.941	99.1	37.3
20.586	48.7	9.3	10.778	73.9	23.3	5.869	99.7	37.6
20.29	49.3	9.6	10.636	74.5	23.6	5.798	100.2	37.9
20.096	49.6	9.8	10.542	74.8	23.8	5.728	100.8	38.2
19.809	50.2	10.1	10.404	75.4	24.1	5.658	101.3	38.5
19.526	50.7	10.4	10.312	75.7	24.3	5.59	101.8	38.8
19.34	51.1	10.6	10.177	76.3	24.6	5.522	102.4	39.1
19.065	51.6	10.9	10.088	76.6	24.8	5.456	102.9	39.4
18.884	52	11.1	9.956	77.2	25.1	5.39	103.4	39.7
18.616	52.5	11.4	9.869	77.5	25.3	5.326	104	40
18.352	53.1	11.7	9.741	78.1	25.6	5.262	104.5	40.3
18.179	53.4	11.9	9.614	78.6	25.9	5.199	105.1	40.6
17.503	54.9	12.7	9.53	79	26.1	5.137	105.6	40.9
17.339	55.2	12.9	9.407	79.5	26.4	5.076	106.2	41.2
17.095	55.8	13.2	9.325	79.9	26.6	4.995	106.9	41.6
16.856	56.3	13.5	9.205	80.4	26.9	4.936	107.4	41.9
16.698	56.7	13.7	9.086	81	27.2	4.877	108	42.2
16.465	57.2	14	9.007	81.3	27.4	4.82	108.5	42.5
16.312	57.6	14.2	8.891	81.9	27.7	4.763	109	42.8
16.085	58.1	14.5	8.815	82.2	27.9	4.688	109.8	43.2
15.935	58.5	14.7	8.702	82.8	28.2			

## 17. Program Parameter Listing

### Farm Hand Vent Master 24

# *Programming*

## (Vent Master 24)

### PSD Room Temperature Display

100= Sensor 1  
020= Sensor 2  
120= Average of Sensors 1 & 2  
003= Sensor 3  
103= Average of Sensors 1 & 3  
023= Average of Sensors 2 & 3  
123= Average of Sensors 1, 2 & 3

### P 1-9 Stage Programming

P1 = Stage Sensor  
100= Sensor 1  
020= Sensor 2  
120= Average of Sensors 1 & 2  
003= Sensor 3  
103= Average of Sensors 1 & 3  
023= Average of Sensors 2 & 3  
123= Average of Sensors 1, 2 & 3

P2 = Stage Mode  
1= Heat Mode  
2= Cool Stir Mode  
3= Cool Neg. Mode  
4= Cool Neg. Tunnel Mode  
5= Cool Tunnel Mode

P3 = Timer Status  
0= Stage Not On Timer  
1= Stage On Timer  
2= Stage is On Cool Timer

### P 10-19 Variable/Cool Timer

P10 = Min. Runtime Percentage  
P11 = Motor Curve Selection

### P 20-29 Vent Machine

P20 = Vent Machine Time Delay (sec.)  
P21 = Static Pressure Differential  
P22 = Tunnel Target Pressure  
P25 = Tunnel "On" Temperature  
P26 = Tunnel "Off" Temperature

### P 30-39 Pressure Ramping

P30 = Ramping ON/OFF  
P31 = High Temp Limit  
P32 = High Temp Target Pressure  
P34 = Low Temp Limit  
P35 = Low Temp Target Pressure

### P 40-49 Hired Hand Network

P40 = Network Address  
P41 = Software Version  
P42 = Controller Setup  
P43 = Stage Expansion  
P44 = Zone Brooder Expansion

### P60-69 Alarm Functions

P60 = Low Pressure Limit  
P61 = High Pressure Limit  
P63 = Cycle Pressure

### P70-79 Timer Settings

P70 = Cool Timer Max. Percentage  
P71 = Cool Timer Min. Percentage

### PS Sensor Calibration

PS1 = Sensor 1  
PS2 = Sensor 2  
PS3 = Sensor 3  
PS4 = Sensor 4

4501-6060

## 18. Error Code Listing

Error Code	Description	Sensor 1 Error	Sensor 2 Error	Sensor 3 Error	Sensor 4 Error	Pressure Error
E1	Sensor 1 Error	X				
E2	Sensor 2 Error		X			
E3	Sensor 1 & 2 Error	X	X			
E4	Sensor 3 Error			X		
E5	Sensor 1 & 3 Error	X		X		
E6	Sensor 2 & 3 Error		X	X		
E7	Sensor 1,2 & 3 Error	X	X	X		
E8	Sensor 4 Error				X	
E9	Sensor 1 & 4 Error	X			X	
E10	Sensor 2 & 4 Error		X		X	
E11	Sensor 1,2 & 4 Error	X	X		X	
E12	Sensor 3 & 4 Error			X	X	
E13	Sensor 1,3 & 4 Error	X		X	X	
E14	Sensor 2,3 & 4 Error		X	X	X	
E15	All Sensor Error	X	X	X	X	
E32	Static Pressure Cycle Error					X
E64	High Static Pressure Error					X
E128	Low Static Pressure Error					X

**Note:** There are other error codes that are possible since there are too many possibilities to list. Any error codes that are encountered other than the ones listed above should be reported to Hired Hand to determine the cause of the error.

## 19. Program Data Sheet

Use this Data Sheet to record your personal settings for the Vent Master 24. Copy this form as needed.

# Farm Hand Vent Master 24

Page 1

Target Temp.	
Target Pressure	
PSD	
Timer %	

Status Switches	
Swx 1 Lock	On/Off
Swx 2 Units	On-Eng./Off Met.
Swx3 Timer	On-10/Off-5
Swx 4 Sensor 3	On/Off
Swx 5 Split Vent Units	On-/Off
Swx 6	ON – mm H <sub>2</sub> O OFF - Pascals
Swx 7 Initiate Defaults	
Swx 8 Program	On-B/Off-A

Tunnel Switches	
Swx 1 Tunnel On	On/Off
Swx 2 Initiate	On-Stage/Off-Outside
Swx 3 Unused	
Swx 4 Split Target Pressures	

Stages	Equipment	OnPoint	OffPoint	P1 Sensors	P2 Mode	P3 Timer
1						
2						
3						
4						
5						
6						
7						
8						
9						
10						
11						
12						
13						
14						
15						
16						
17						
18						
19						
20						
21						
22						
23						
24						

# Farm Hand Vent Master 24      Page 2

P20 Vent Machine Time Delay	Sec.
P21 Static Pressure Differential	
P22 Tunnel Target Pressure	
P25 Tunnel "On" Temp	
P26 Tunnel "Off" Temp	
P30 Ramping ON/OFF	
P31 High Temp Limit	
P32 High Temp Target Pressure	
P34 Low Temp Limit	
P35 Low Temp Target Pressure	

P40 Network Address	
P41 Software Version	
P42 Controller Setup	
P43 Stage Expansion	
P44 Zone Brooder Expansion	
P60 Low Pressure Alarm	
P61 High Pressure Alarm	
P63 Cycle Pressure Alarm	
P70 Cool Timer Max. %	
P71 Cool Time Min. %	

**P1 Sensors**

- 100=Sensor 1
- 020=Sensor 2
- 120=Avg. Sen 1&2
- 003=Sensor 3
- 103=Avg. Sen 1&3
- 023=Avg. Sen 2&3
- 123=Avg. Sen 1,2&3

**P2 Mode**

- 1=Heat
- 2=Cool Stir
- 3=Cool Neg
- 4=Cool Neg Tunnel
- 5=Cool Tunnel

**P3 Timer**

- 0=Off Timer
- 1=On Normal Timer
- 2=On Cool Timer



**HIRED-HAND<sup>®</sup>**